

For Your Quality
Production And Safety





ETH Engineering was established in 2017
ETH Engineering has adopted corporate approaches and aims
to differentiate itself through customer orientation and creativity.

ETH Engineering Coil and Sheet metal handling equipment manufacturing,
Plant relocation, Industrial Plant Installation, It is an engineering company
specialising in Machine Design and Manufacturing,
Industrial Maintenance and Overhaul services..

ethmühendislik

"Provides solutions to your needs."



HORIZONTAL COIL TONG

• eth •

It is used for horizontal coil transport. It has bidirectional infinite rotation feature.

With 3 different body options, it can also be used for conveying wide coils allows.

- Load sensing mechanism
- Arm closing mechanism
- Coil centring sensor (4 pcs.)

Load sensing and arm closing switches increase the safety of the load, equipment and user.

Coil centring sensors warn the operator by lighting the green warning light when the arms centre the coil, activates the arm closing function and prevents the arms from hitting the coil and damaging the coil.

All our products are CE certified,
All our products can be designed and manufactured in accordance with the special needs and demands of the customer.



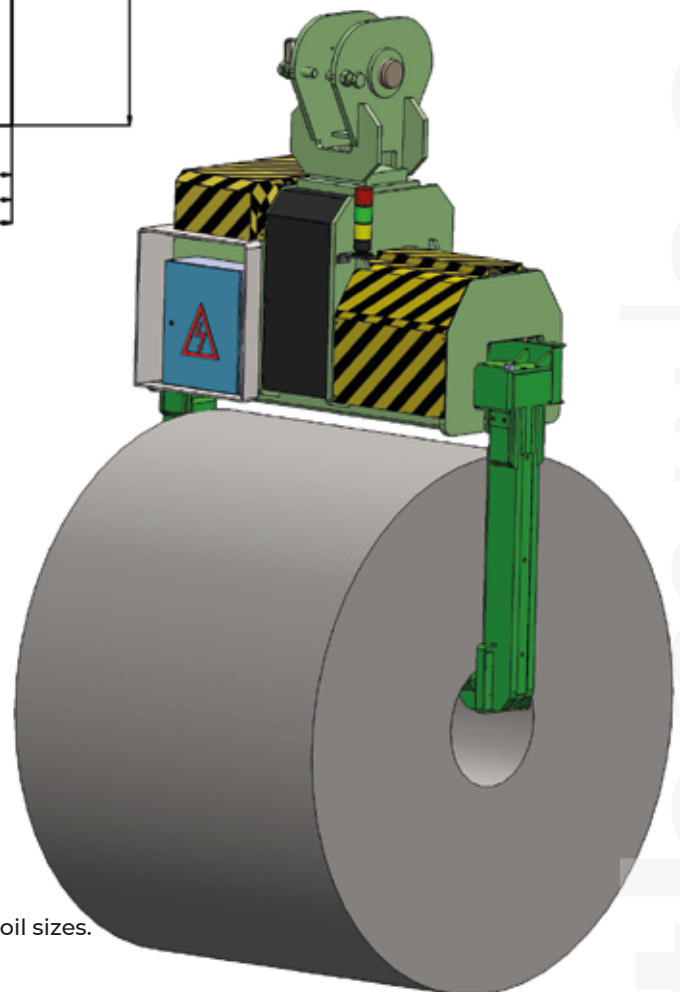
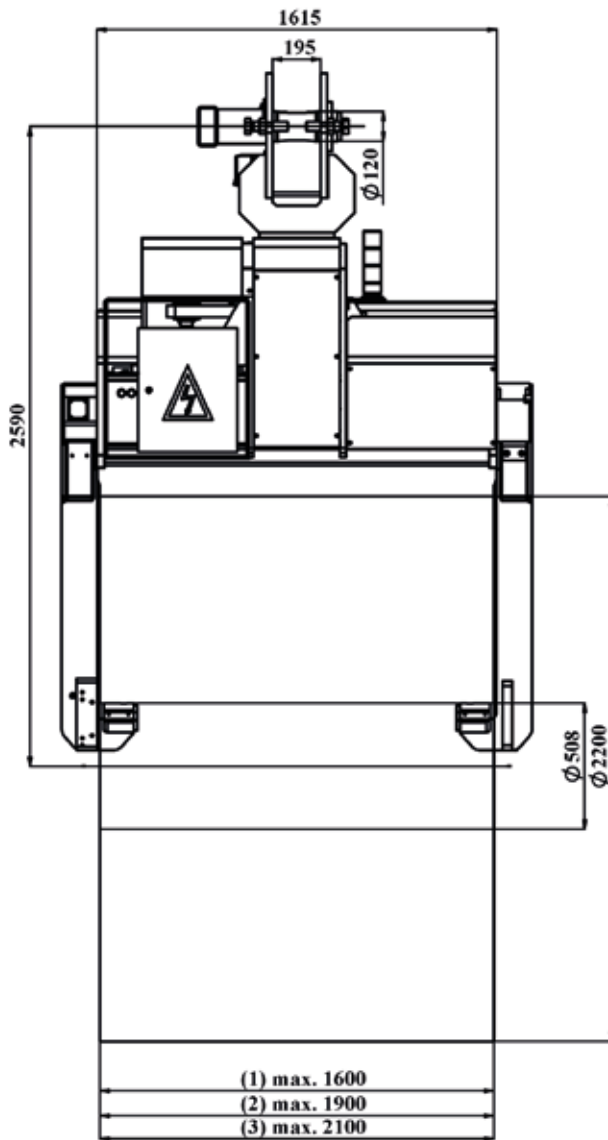

Technical Features

Coil Width (min.-max.) 1:	600 - 1600 mm
Coil Width (min.-max.) 2:	600 - 1900 mm
Coil Width (min.-max.) 3:	600 - 2250 mm
Coil Diameter (max.):	2200 mm
Load Capacity (max.):	20, 30, 40 ton
Coil Inner Diameter:	508 - 610 mm

*Design can also be made for non-standard special coil sizes.

i

Whatsapp
Line:

ethmuhendislik

ethmuhendislik

SHEET PACK TONG



Palletised Sheet Product Transport Tong

- Load sensing mechanism
- Arm closing mechanism
- 360° Infinite rotation feature
- Load sensing and arm closing switches increase the safety of the load, equipment and user
- Arm extension can also be motorised.

All our products are CE certified, all our products can be designed and manufactured in accordance with the special needs and demands of the customer.



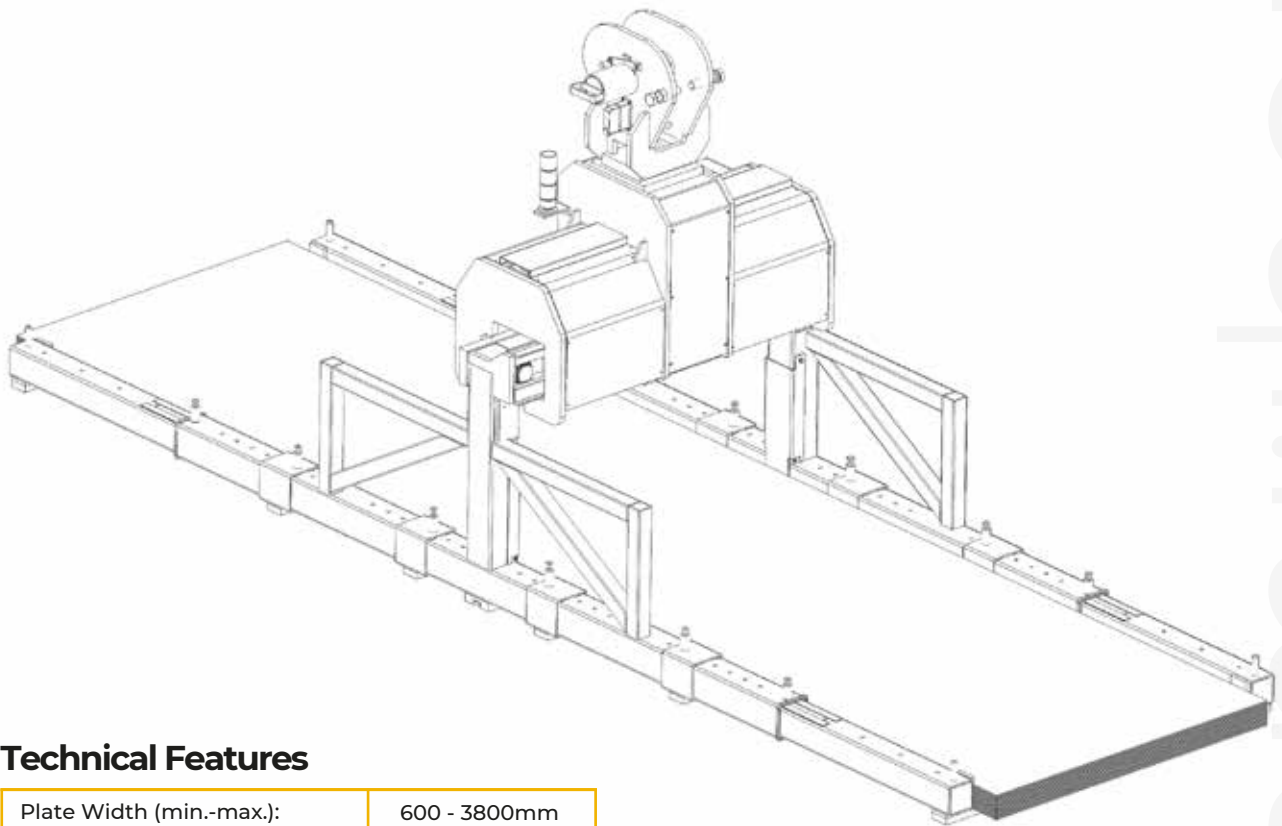
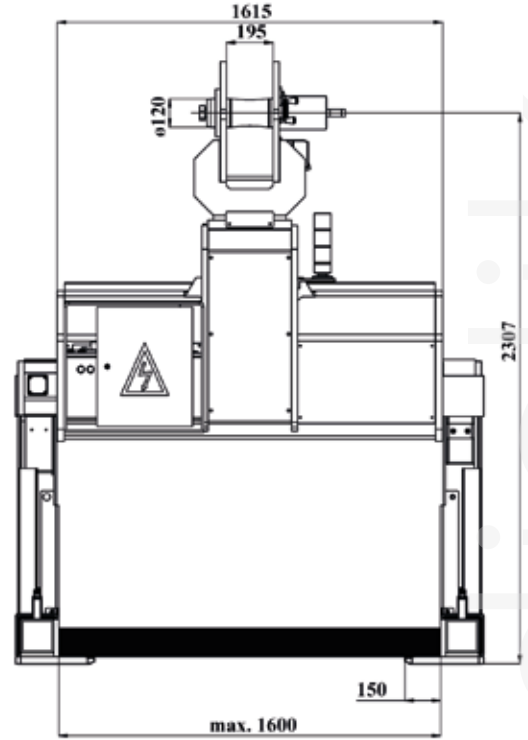
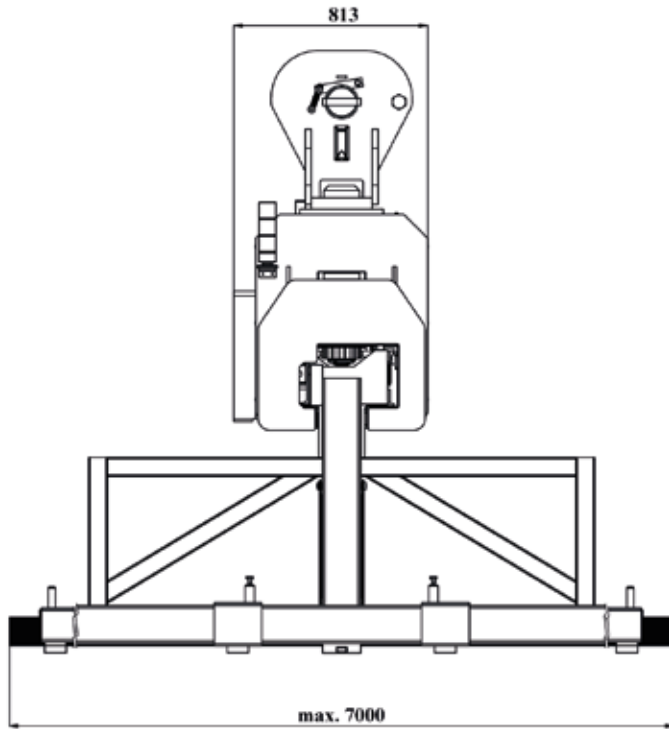

Technical Features

Plate Width (min.-max.):	600 - 3800mm
Plate Length (max.):	15000mm
Load Capacity (max.):	25 ton

*Design can also be made for non-standard special plate sizes.

i

Whatsapp
Line:

MECHANICAL VERTICAL COIL TONG



This equipment is used for loading and unloading of bell type furnaces in cold rolling mills and also for handling of coils to be shipped vertically.

Since there is no electrical equipment on the equipment, the possibility of failure is low. It can be produced with single jaw and two jaws.

All our products are CE certified,
Light and audible warning features can be included in the equipment upon request.
All our products are customised to the specific needs and demands of the customer can be designed and manufactured accordingly.



Whatsapp Line:  

For More:  



eth mühendislik

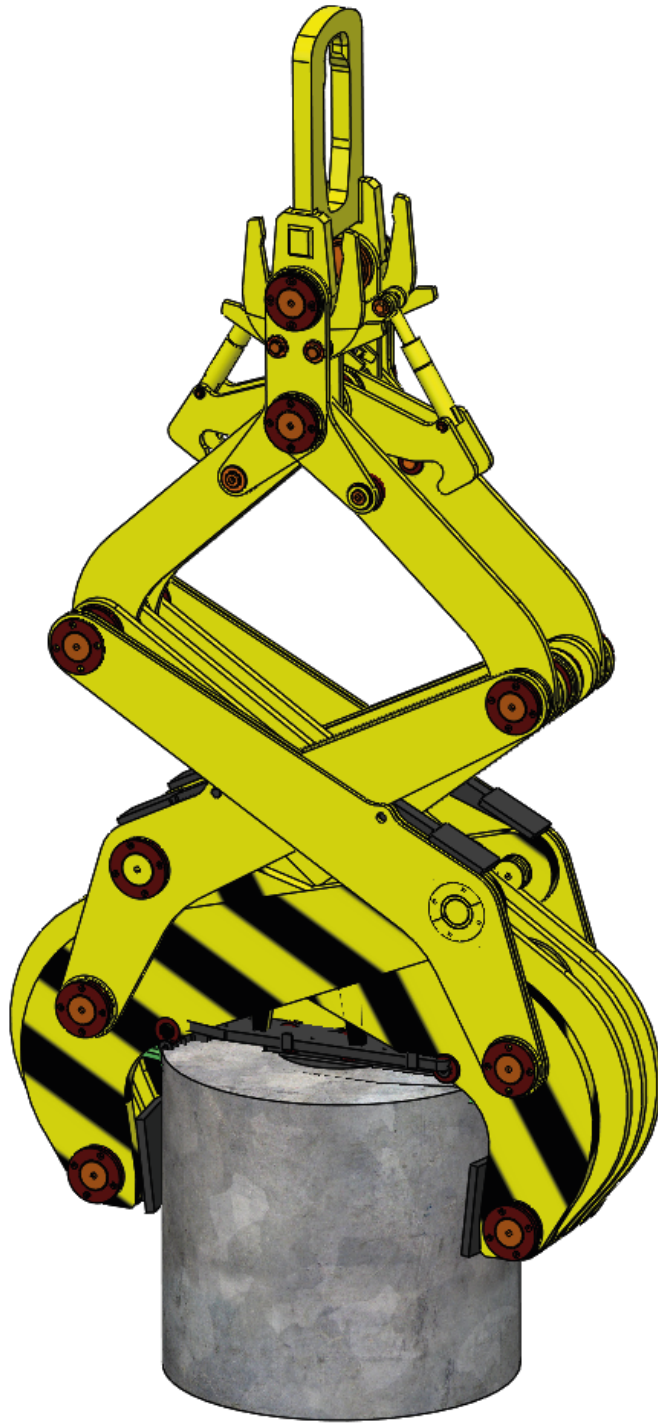

Technical Features

Coil Inner Diameter:	508 - 610 mm
Coil Width (min.-max.):	600 - 1500 mm
Coil Diameter (min. - max.):	1000-2100 mm
Load Capacity (max.):	35 ton
Max. Clearance Length:	6400 mm

*Design can also be made for non-standard special coil sizes.



VERTICAL COIL TONG FOR COILS WITH PALLETS

• eth •



It is used for the transport of sliced upright products of various widths on pallets in the factory and for the transport of packaged palletised products to the customer.

- Load sensing mechanism
- Arm closing mechanism
- 360° Infinite rotation feature

All our products are CE certified, All our products can be designed and manufactured in accordance with the special needs and demands of the customer.

*The safety of the load, equipment and user is ensured with load sensing and arm closing switches.



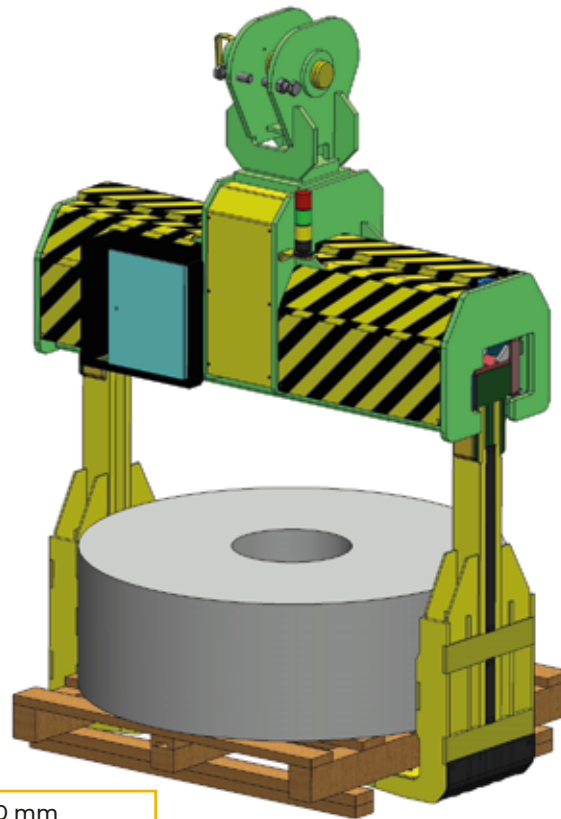
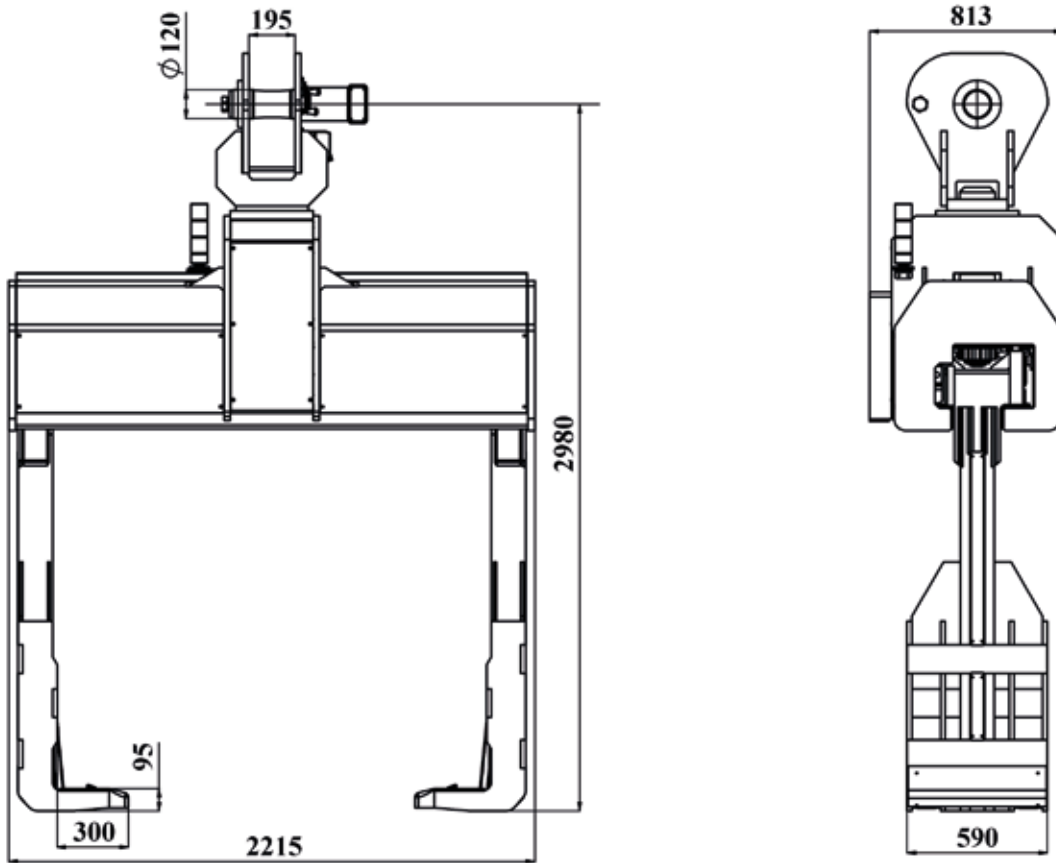

Technical Features

Coil Width (max.):	1300 mm
Coil Diameter (min. - max.):	700 - 1800 mm
Load capacity (max.):	15 ton

*Design can also be made for non-standard special coil sizes.



ethmuhendislik

ethmuhendislik

HORIZONTAL COIL HANDLING TONG WITH FOLDABLE FEET

• eth •



It is used for Horizontal Coil Dispatching. It has bidirectional infinite rotation feature. With the folding feature of the coil catching feet, the gaps between the coils in the coil stock areas are minimised and the occupancy in the stock areas is increased..

- Load sensing switch mechanism
- Arm closing switch mechanism
- Coil centring sensor (4 pcs.)

* The safety of the load, equipment and user is increased with load sensing and arm closing switches.

Coil centring sensors warn the operator by lighting the green warning light when the feet centres the coil, ensures that the foot closing function is active, prevents the feet from hitting the coil and damaging the coil.

All our products are CE certified, all our products can be designed and manufactured in accordance with the special needs and demands of the customer.

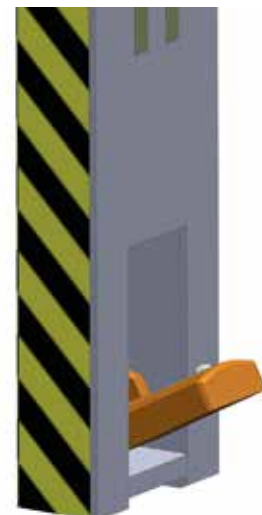
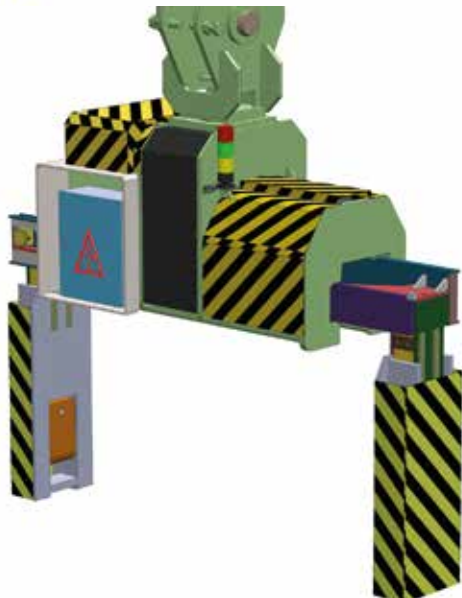
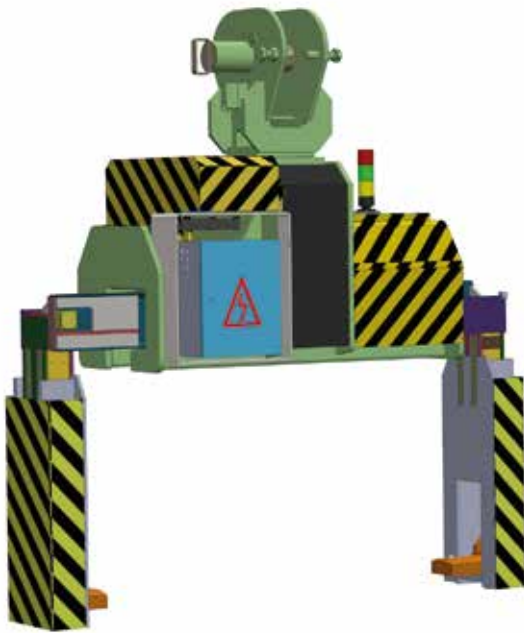

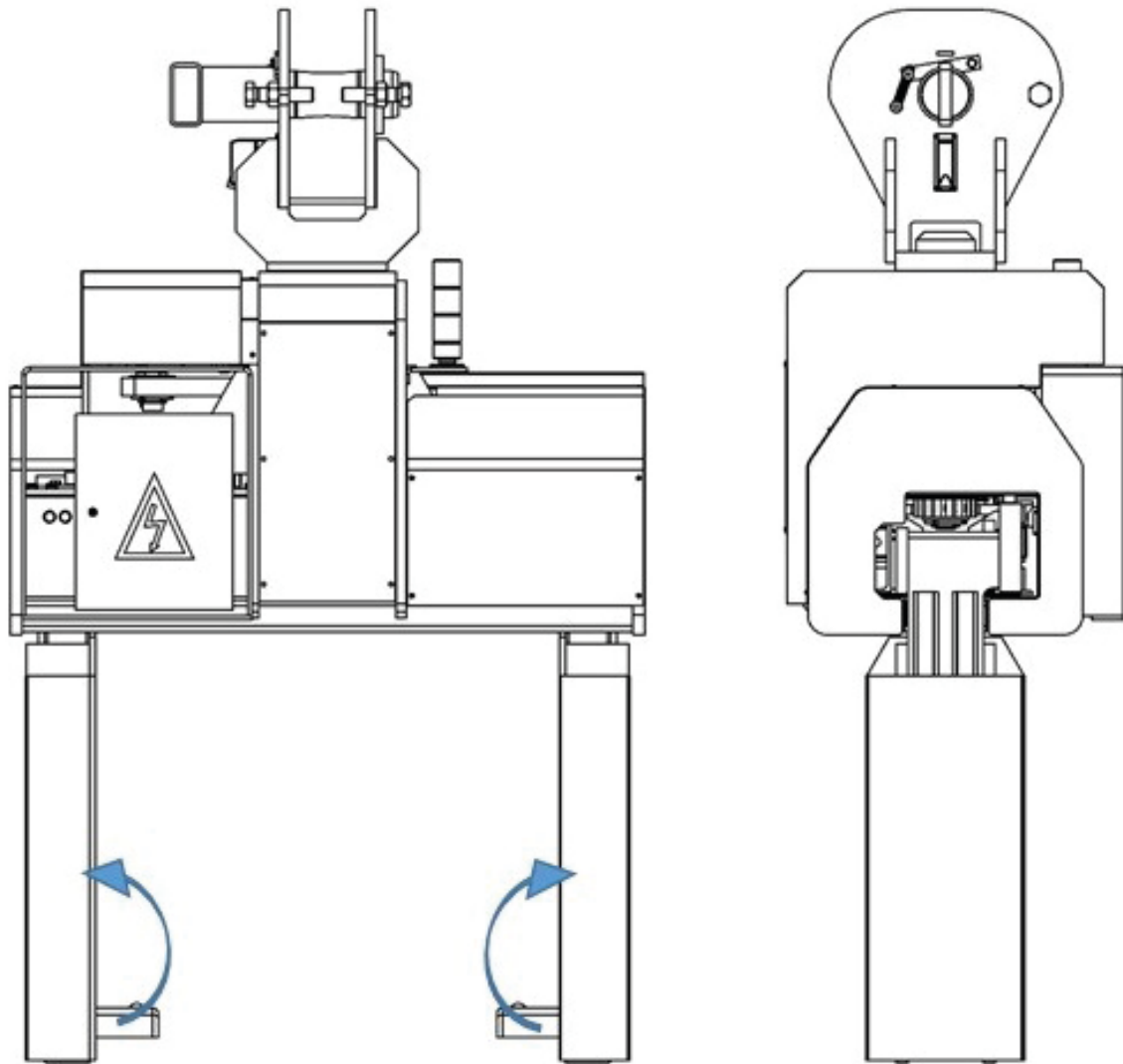

Technical Features

Coil Width (min.-max.) 1:	600 - 1600 mm
Coil Width (min.-max.) 2:	600 - 1900 mm
Coil Width (min.-max.) 3:	600 - 2100 mm
Coil Diameter (max.):	2200 mm
Load capacity (max.):	30 ton
Coil inner Diameter:	508 - 610 mm

*Design can also be made for non-standard special coil sizes.



ethmuhendislik

ethmuhendislik



It is used for transport and handling of horizontally stocked coils and slitted narrow belts. It has bidirectional infinite rotation feature. By using balance weight, the hook position is kept at safe angles. It has a special design to prevent damage to the inner surface of the coil. Damage to the coil is prevented with side wall coverings.

The desired rotation position can be achieved with the brake drive motor.

All our products are CE certified, All our products can be designed and manufactured in accordance with the special needs and demands of the customer.



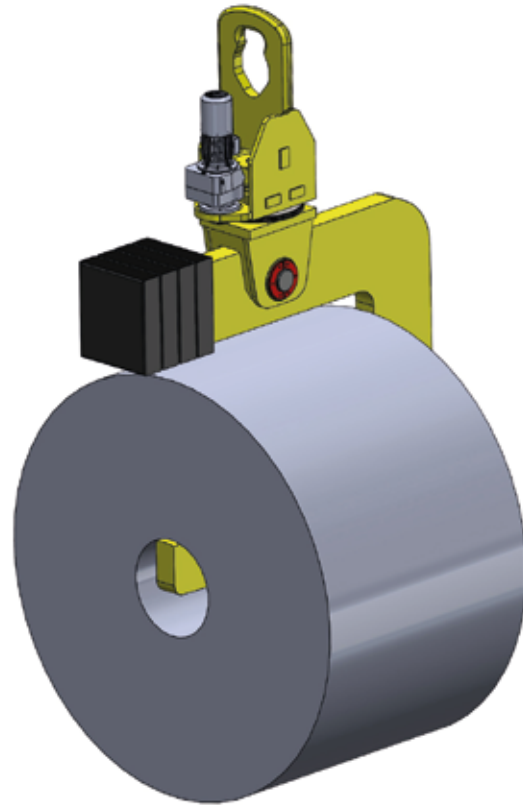
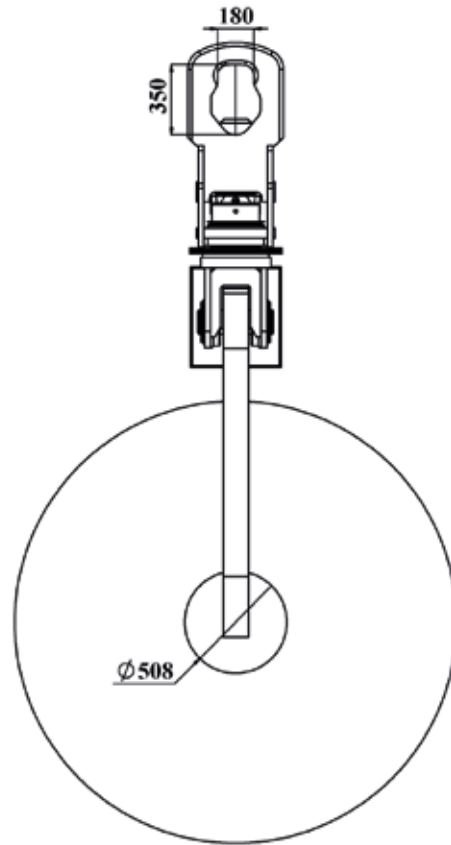
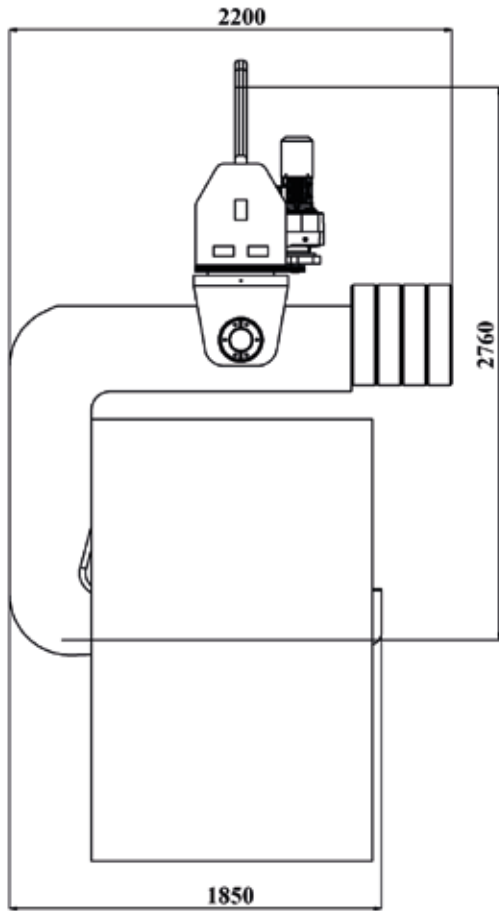

Technical Features

Coil Width (max.):	1750 mm
Coil Diameter (max.):	2200 mm
Load capacity (max.):	35 ton
Coil Inner Diameter:	508 - 610 mm

*Design can also be made for non-standard special coil sizes.



ethmuhendislik

ethmuhendislik

“C” HOOK WITH CHAIN / WITHOUT CHAIN

• eth •

It is used for the transport and handling of horizontally stacked coils and slitted narrow belts.

By using balance weight, the hook position is kept at safe angles. It has a special design to prevent damage to the inner surface of the coil. Damage to the coil is prevented by side wall coverings.

All our products are CE certified,
All our products can be designed and manufactured in accordance with the special needs and demands of the customer.

Whatsapp
Line:



For
More:



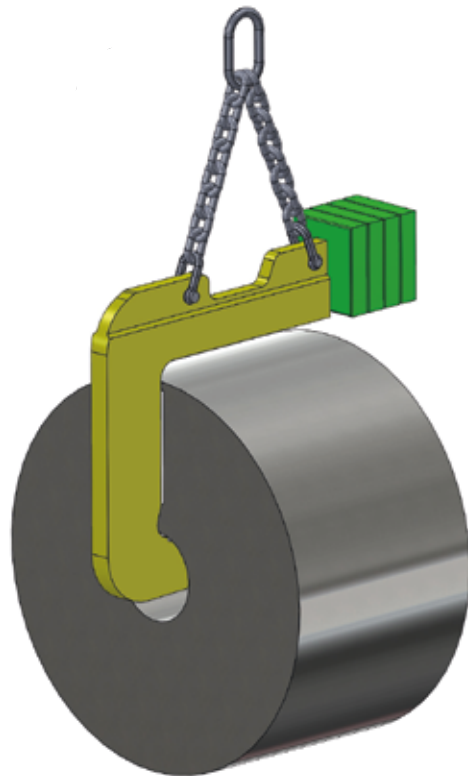
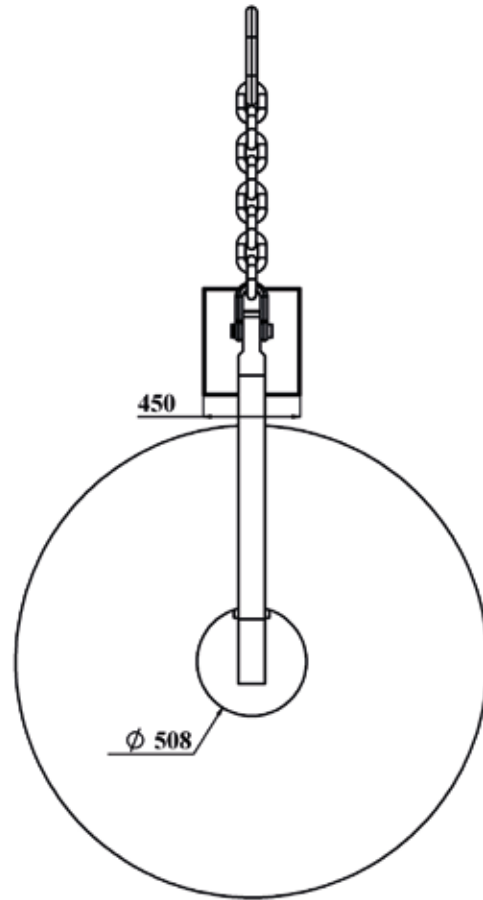
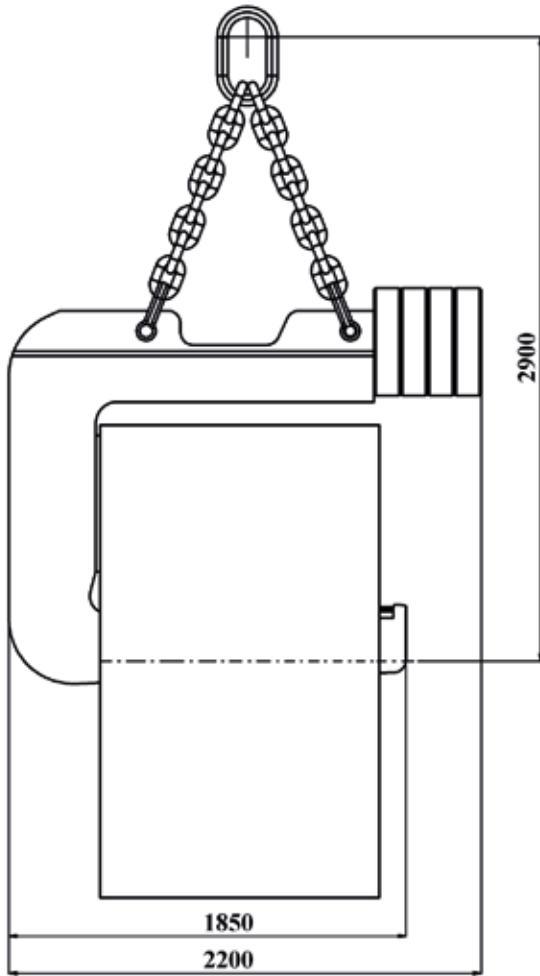

Technical Features

Coil Width (max.):	1300 mm
Coil Diameter (max.):	2200 mm
Load capacity (max.):	35 ton
Coil inner Diameter:	508 - 610 mm

*Design can also be made for non-standard special coil sizes.



ethmuhendislik

ethmuhendislik

Used for the transport of vertical coils.

Technical Features

Coil Width (max.):	1300 mm
Coil Diameter (max.):	2200 mm
Load capacity (max.):	30 ton

*Design can also be made for non-standard special coil sizes.



VERTICAL COIL TONG WITH MOTORIZED INTERNAL GRIP

It works with mechanical scissor system.

There is no electrical equipment on it. Fully open and fully closed positions are provided by cam lock system. With horizontal coil transport mechanical attachment The coil is transported horizontally from the stocked coil by holding it with the attachment arms. Attachment arms cam system is switched to open and closed position.

When the coil reaches the point to be dropped, the crane drops the coil to the place where it is desired to be lowered. After the coil touches the ground, the scissors switches to the closing position and the opened arms are removed from the coil. In this way, the operation is realised.

All our products are CE certified, all our products are designed and manufactured in accordance with the special needs and demands of the customer, can be manufactured. Light and audible warning features can be included in the equipment upon request

Technical Features

Capacity (max.):	3 - 15 ton
Coil Diameter (max.):	750 - 2000 mm
Coil Width (max.):	750 - 1400 mm



TILTING "C" HOOK / VERTICAL NARROWBAND ATTACHMENT

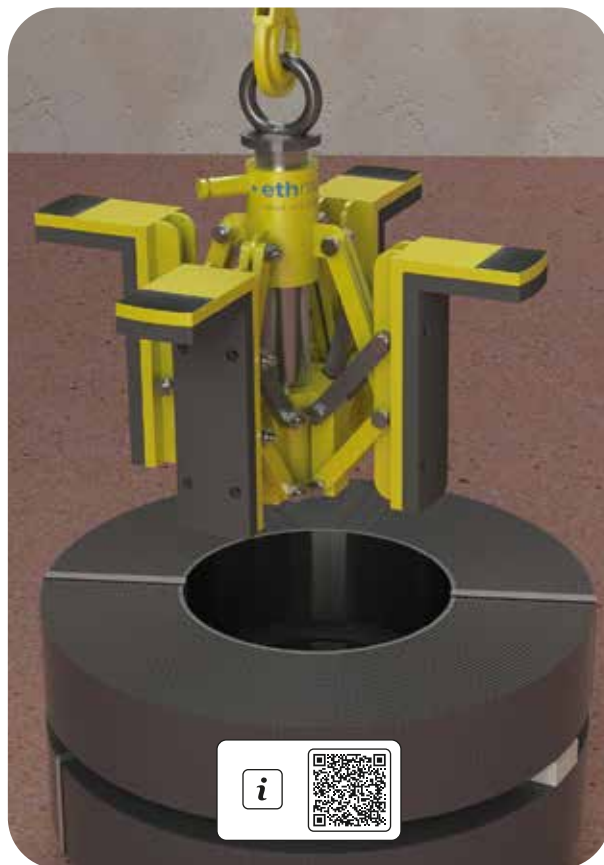

*Light and audible warning features can be included in the equipment upon request.

ROTATING HOOK



In general, when transporting loads with standard crane hooks, operators have to intervene in the load in order to guide the load being transported. This poses a risk in terms of occupational safety.

By making the crane hook controllable and motorised rotation, the crane operator can intervene by turning the load left and right by remote control during the operation.

All our products are CE certified, all our products can be designed and manufactured in accordance with the special needs and demands of the customer.



VERTICAL COIL TONG WITH MECHANICAL INTERNAL GRIP

Capacity: 1 - 10 ton between

It works with mechanical scissor system. There is no electrical equipment on it. Fully open and fully closed positions are provided by cam lock system.

CE certified

Design and production are made according to customer diameter and weight demands.

Mechanical vertical coil attachment with inside grip. The attachment legs are inserted into the inner core of the vertically stocked coil and the cam system is switched to the open position, opening the shear and the clamping process takes place. The crane lifts the attachment up and the clamping and transport process is carried out. When the coil reaches to the point where the coil is to be dropped, the crane lifts the coil to the floor. After the coil touches the floor, the scissors switch to the closing position, The narrowed legs are removed from the coil. In this way, the operation is completed.

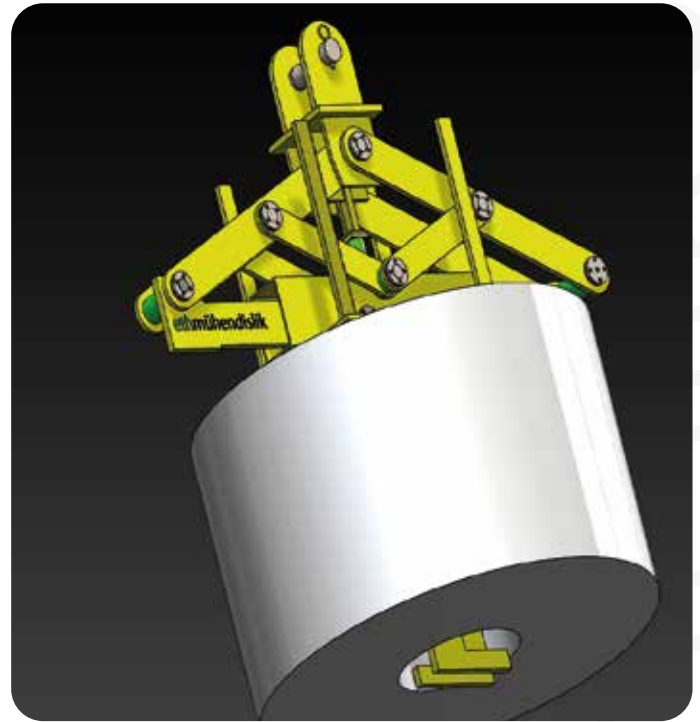

All our products are CE certified, All our products can be designed and manufactured in accordance with the special needs and demands of the customer. Light and audible warning features can be included in the equipment upon request

VERTICAL COIL TONG WITH MOTORIZED INTERNAL GRIP

Capacity: 1 - 15 ton between

It is used for transporting and handling vertically stacked bobbins. The arms are inserted into the inner core of the coil in the minimum gap position. With the electric motor drive, the arms are opened and the approach sensors are brought closer until they touch the inner surface of the coil, then they are lifted upwards so that the load safety sensors touch the bottom of the coil. In this way, the coil is gripped securely. In this way, the transport operation is realised. With in-arm proximity sensors and load safety sensors damage to the product is prevented. All movements are motorised and performed remotely, minimising the risk of work accidents.

All our products are CE certified, All our products can be designed and manufactured in accordance with the special needs and demands of the customer.



SLAB TONG



www.ethmuhendislik.com



It is used in the transport and handling of slabs, which are the product of continuous casting plants

Scissor clamping is carried out completely by mechanical or rope system.

It can be designed and manufactured in the range of 10-120 tonnes to carry single or multiple slabs according to preference.

All our products are CE certified, all our products can be designed and manufactured in accordance with the special needs and demands of the customer.



ROLL TRANSFER TONG



www.ethmuhendislik.com



It is used for transporting rolls in cold and hot rolling mill plants. It is used before and after grinding of intermediate rolls (IMR), backup rolls (BUR) and work rolls (WR) used in rolling mill plants and during putting and removing them to the roll change machine.

Design and production are made according to customer size demand.

All our products are CE certified, All our products can be designed and manufactured in accordance with the special needs and demands of the customer.



COIL TRANSFER CAR

• eth •

It is used for transferring coils to different halls in cold and hot rolling mills, stock areas and production halls.

We design and manufacture trolleys with a capacity of 5 - 110 tonnes according to customer demand. All our products are CE certified, all our products can be designed and manufactured in accordance with the special needs and demands of the customer.



COIL TRAILER

• eth •

It is used to transport coils from stock areas to production areas. It is moved by towing with construction machinery or tractor. Products such as pipe profile can also be transported with flat ground.

According to customer demand, products with a capacity of 5 to 40 tonnes are designed and manufactured. All our products are CE certified, all our products can be designed and manufactured in accordance with the special needs and demands of the customer. Light and audible warning features can be included in the equipment upon request.





It is used to bring the coils in the enterprise to vertical or horizontal position according to the operation requirement. It is also used to rotate machinery and equipment without damaging them in heavy and sensitive works such as maintenance of rolling mill roll bearings.

According to customer demand, products with a capacity of 5 to 35 tons are designed and manufactured.

All our products are CE certified, all our products can be designed and manufactured in accordance with the special needs and demands of the customer.



ethmühendislik

It is used for long product and pipe transport and loading purposes. Cargo can be transported by hanging the load with chain and steel sling from different points. It can be used for loads of different lengths with modular additional parts. At the same time, easy and safe operations can be carried out in narrow spaces with magnetised traverse.

*Light and audible warning features can be included in the equipment upon request.



Packaged Flat Product Transport Traverse



Lamellar Hook Carriage Traverser



Rolling Mill Roller Transport Traverse



Rotary Traverse

It can be modularly used for loads of different lengths with additional parts.

All our products are CE certified, all our products can be designed and manufactured in accordance with the special needs and demands of the customer.



PAPER ROLL HANDLING TONG

• eth •



It is designed for paper main producers and its capacity is between 1 - 10 tonnes.

Roll width is between 750mm - 2500mm.

It provides safe and undamaged application of handling operations between production operations.

The equipment has electromechanical and hydraulic options.

All our products are CE certified, All our products can be designed and manufactured in accordance with the special needs and demands of the customer.



CONVECTOR HANDLING ATTACHMENT

• eth •



It is designed for transporting equipment such as inter-coil convectors and inner liners in stack annealing lines in flat steel plants and for safe loading on the line.

The equipment is mechanically operated. According to customer demand, lifting and handling functions can be visualised with the help of sensors.

All our products are CE certified, all our products can be designed and manufactured in accordance with the special needs and demands of the customer. Light and audible warning features can be included in the equipment upon request.







- Aperam
- Arçelik
- ArcelorMittal
- Assan Alüminyum
- Asil Çelik
- Atakaş Çelik
- Aydemir Metal
- Bağcı Antrepo
- Bamesa
- Bemas Metal
- Betek
- Borçelik
- Borusan Enerji
- Borusan Mannesmann Boru
- Borusan Lojistik
- Borusan Makina ve Güç Sistemleri
- Cesan
- Çağsoy Tekstil
- Çemtaş
- Çimtaş
- Çolakoğlu
- Daikin
- Dalan Kimya
- Diler Demir Çelik
- Elba
- Ekip Steel
- Ermetal
- Eti Makine
- Güralp Vinç
- Gelem Metal
- İlhanlar Demir Çelik
- İntekno
- İpek Kağıt
- İzocam
- JMW Jant
- Kimmco - Isover
- Karataş Demir Çelik
- Konecranes
- Koen mühendislik
- Kerim Çelik
- Kordsa
- Liberty Steel
- Matay
- MF Tube
- MMK Metalurji
- Milangaz
- Modern Karton
- MPS Metal
- Orhangazi Lojistik
- Parsan
- Pfeifer
- Posco - Assan
- Poliran İsrail
- Rekor Kauçuk
- Roda Limanı
- Sarıtaş Paslanmaz
- Silvan
- Siemens
- Trinox
- Tat Metal
- Teknik Alüminyum
- TKG Otomotiv
- Thyssenkrupp
- Tezcan Galvaniz
- Tosyalı
- Valeo
- Vestel
- Varzene
- VIG metal
- Yıldız Demir Çelik
- YC - İnox
- ZMK İnşaat



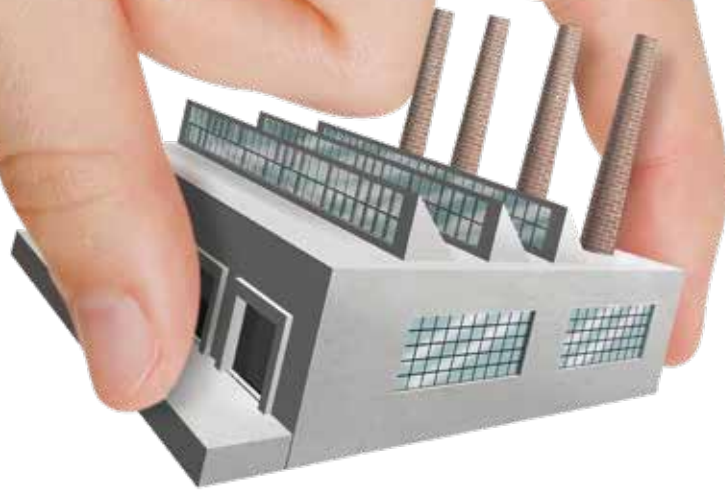

RELOCATING YOUR FACTORY IS EASY FOR US!

ETH Mühendislik, with its experienced and expert staff, provides turnkey transportation service including mechanical, electrical, automation and fluid systems and transportation without distinguishing the sector.

Moreover, you can get service including all new design, manufacturing and assemblies that you will need during installation in your new place.

“Flexible planning, perfect and corporate solution...”

• **eth**muhendislik •



• eth mühendislik •

Technical And Industrial Services consultancy Anonymous Company



+90 (224) 519 06 06



Ata Mah. Küçük Sanayi Sitesi, 201. Sok. No: 9,
Gemlik 16601 Bursa



info@ethmuhendislik.com



www.ethmuhendislik.com

Whatsapp
Line:

